

AVR Lab in Pocket AVRLiP V2

.....
Connection & Assembly Guide



Sectional Schematics

LED Interfacing:

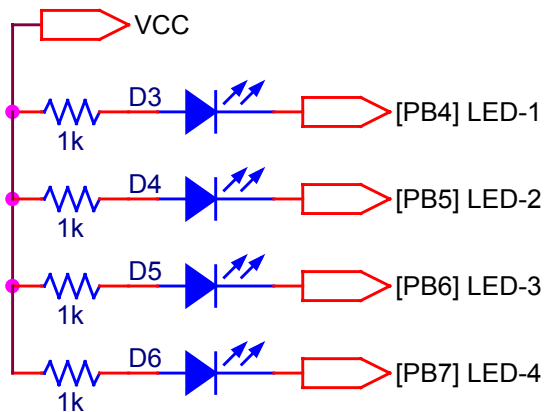

Switch Interfacing

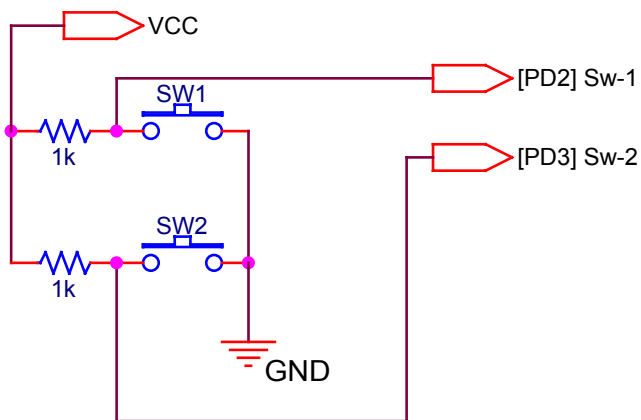

RS232 Interfacing

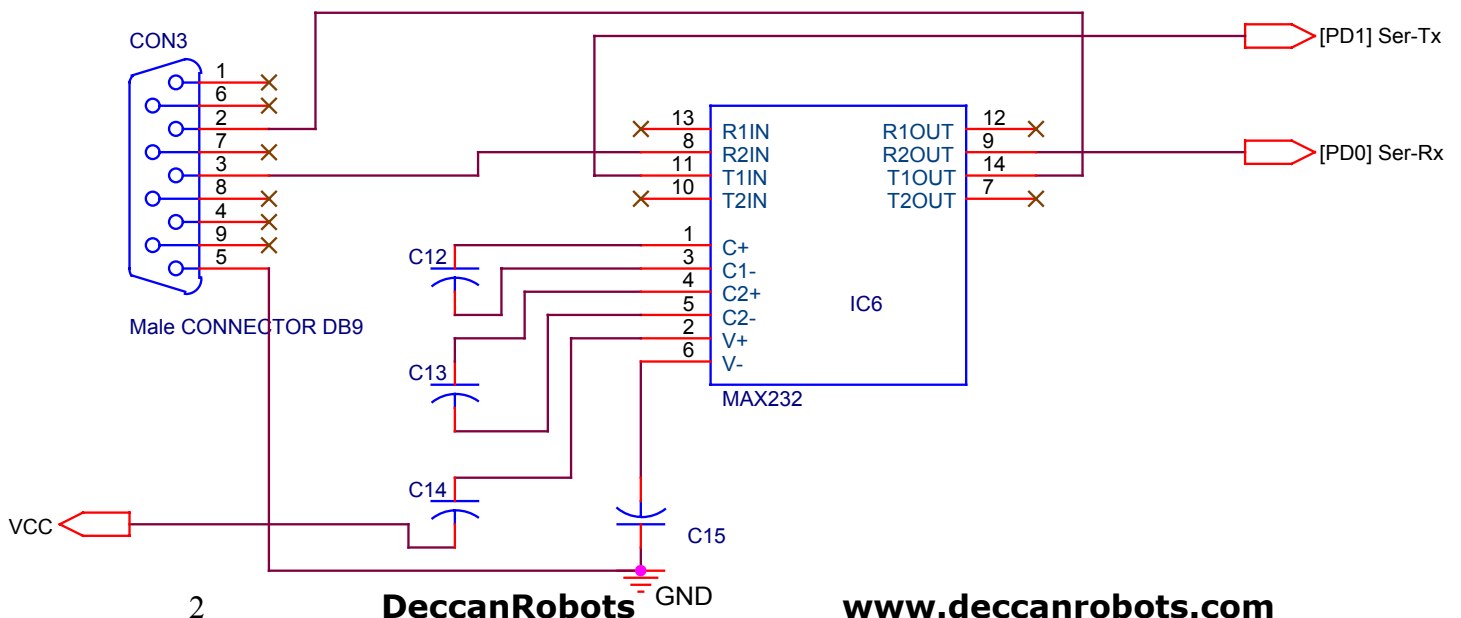

LCD Interfacing

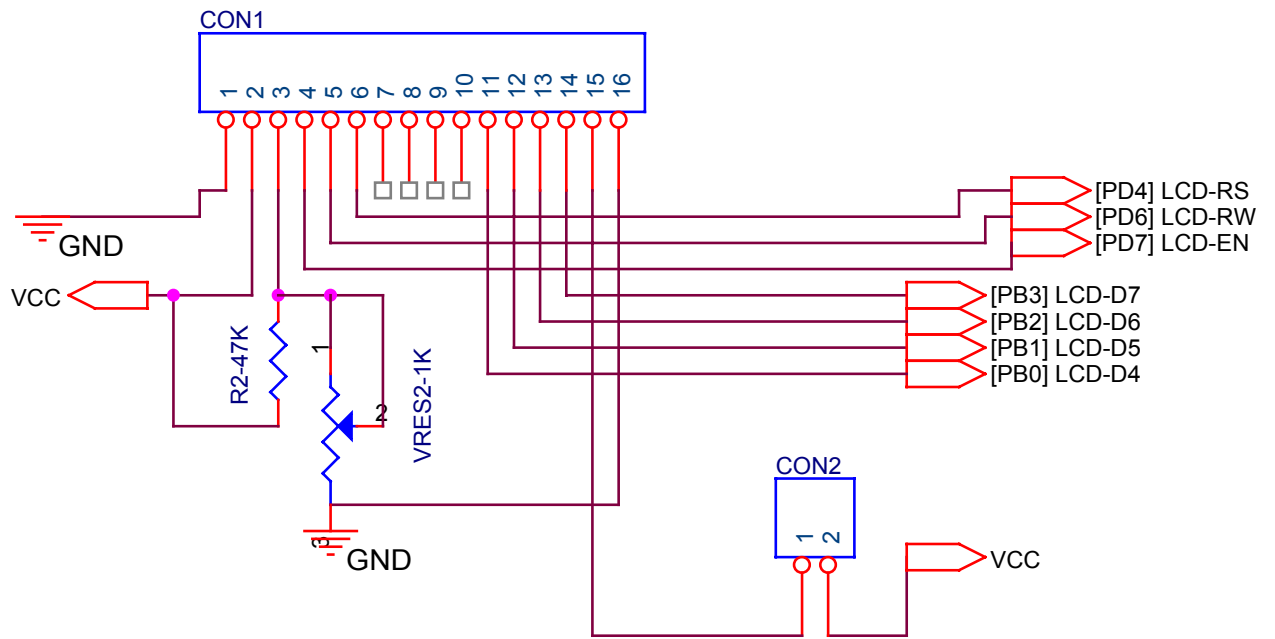

LM35 Temperature Sensor interfacing

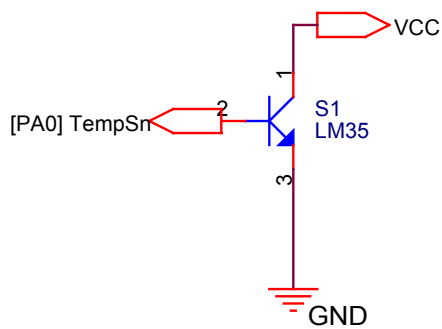

Piezo Buzzer Interfacing

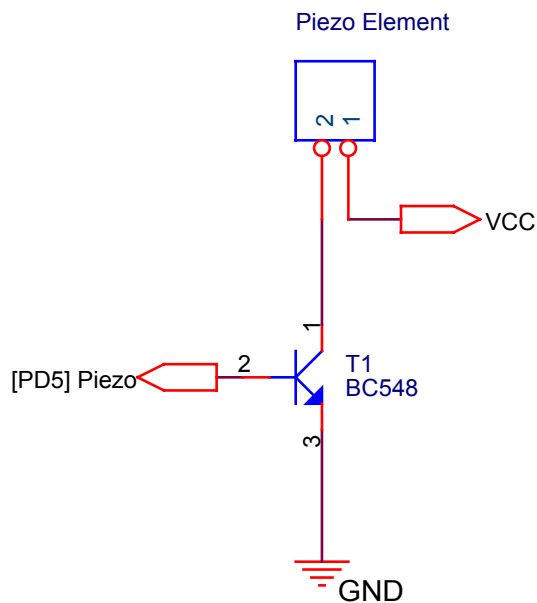

LDR Interfacing

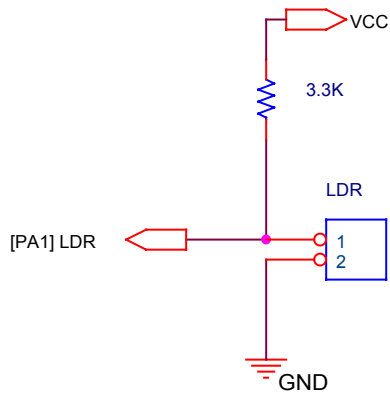

VRES Interfacing

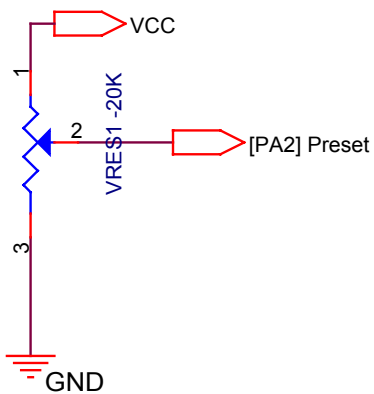

DS1307 RTC Interfacing

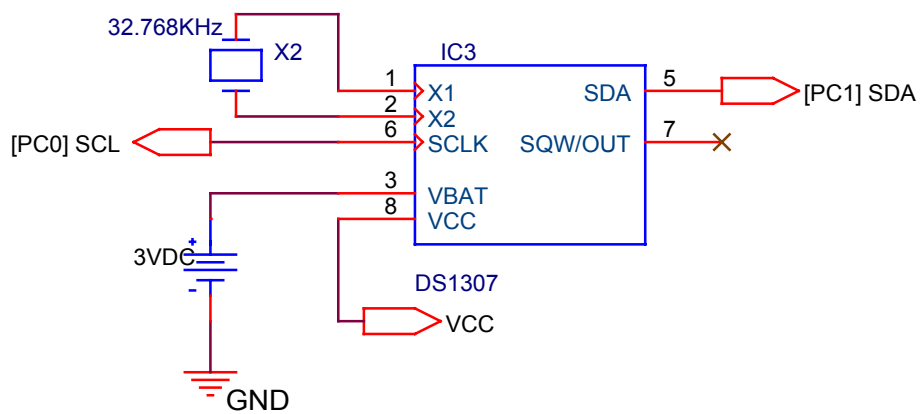

24C256 EEPROM Interfacing

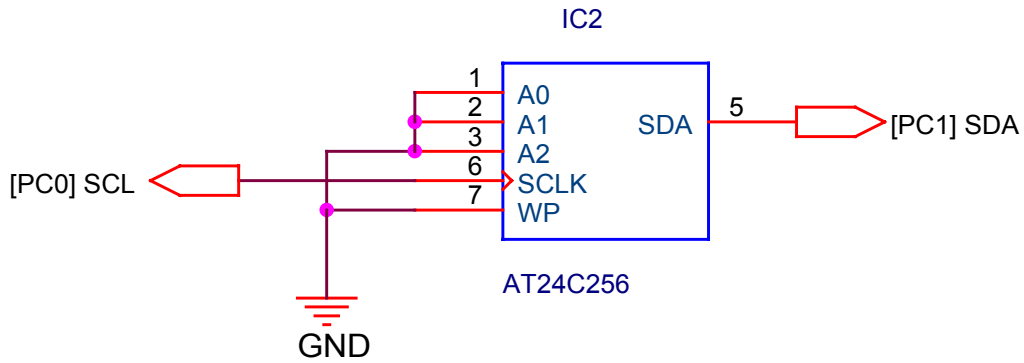

TSOP1738 IR Receiver interfacing

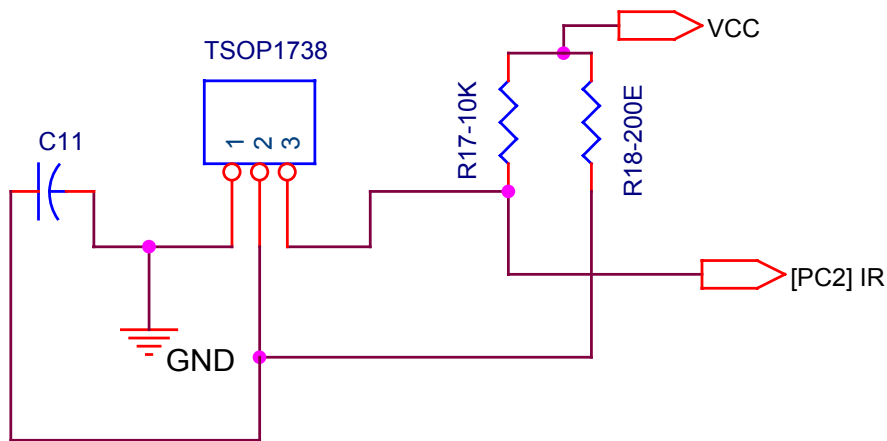

4x4 Keypad interfacing

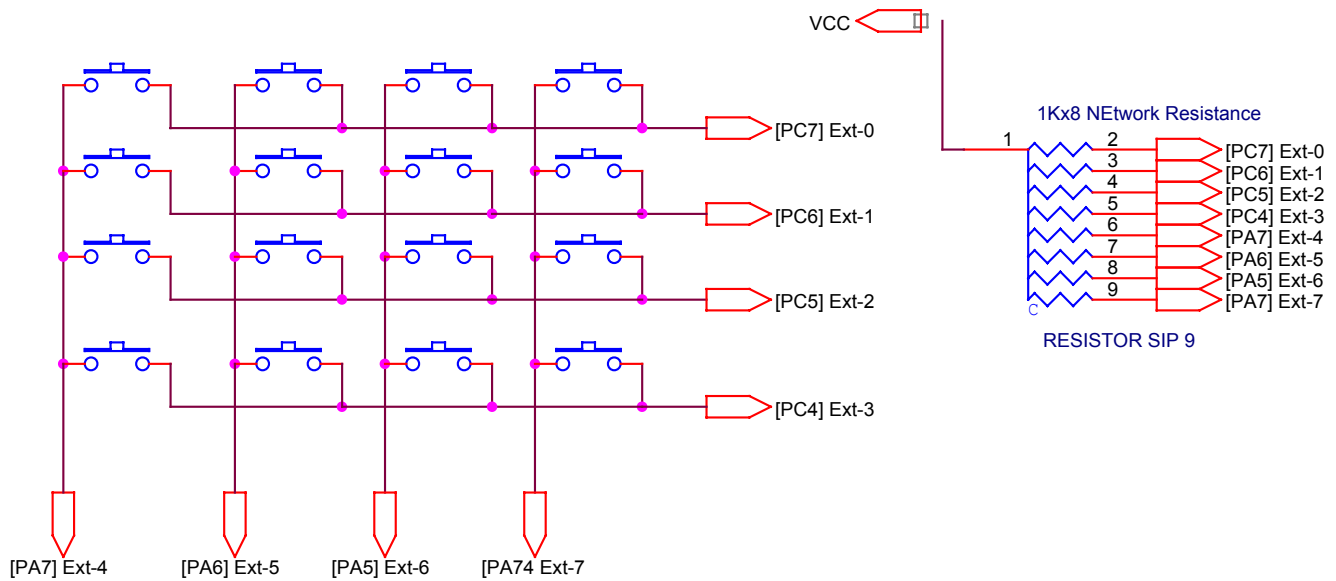

The ATmega32

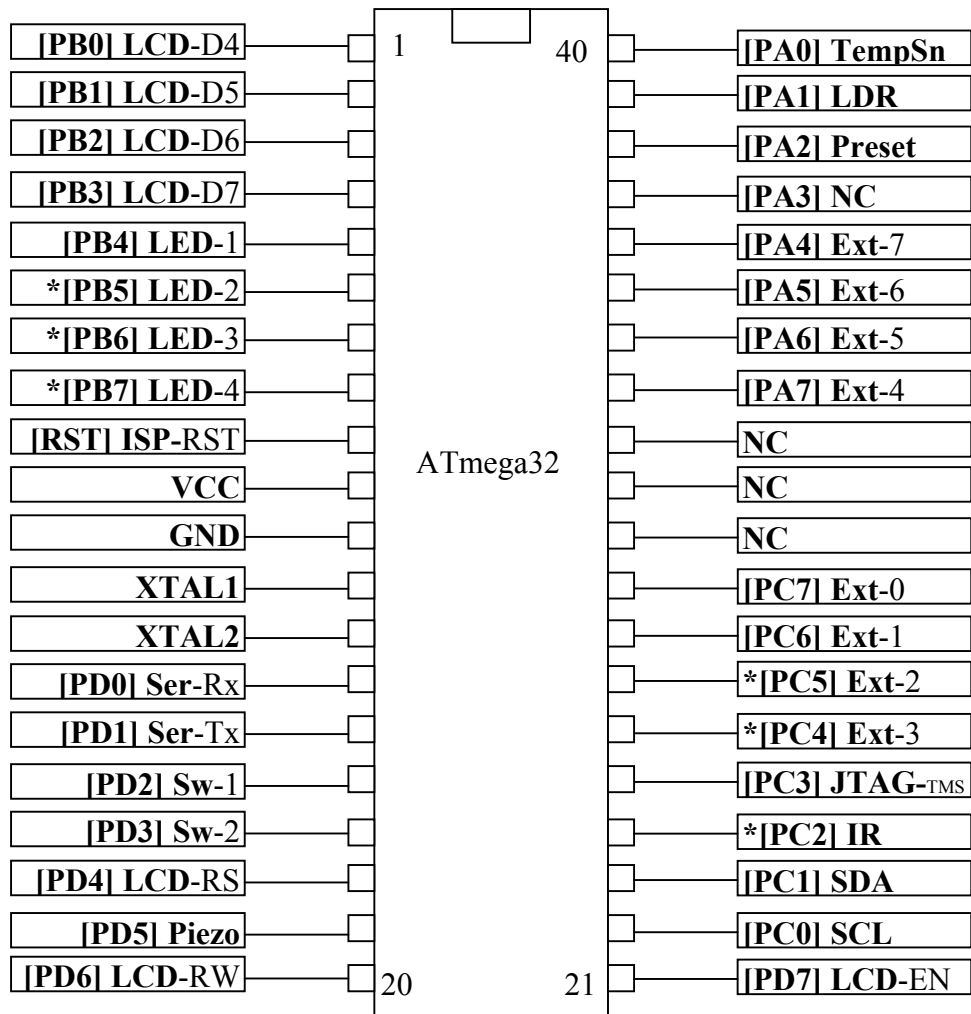

Power Supply:

AVRLiPV2 can be power by following options:

1. Via USB Port:

PC/LapTop =>USB Cable=>AVRLiPv2

This was 5VDC power supply from USB port / cable is used. The USB connector seen in the product image has "no" other functionality.

2. Via 5V Regulated External Power Source.

Locate the CON5 (2 pin male connector on right side) on the PCB and connect a "Regulated 5V DC" supply here. Use of unregulated source of power will damage the board.

3. How to Switch On/Off?

To save the PCB space, a small 2-pin jumper is used to switch ON or Off the AVRLiPV2. This is common for both types of power sources described above. Locate it on left side of the Green LED (Power On Indicator LED).

Programming ATmega32:

There are three options to program ATmega32

1. Via ISP Port

Locate a 6 Pin male connector at center-bottom, just below switches. This is ISP connector, which has Vcc, Gnd, MOSI, MISO, SCK and RST pins from left to right direction. Use any suitable ISP Programmer to program ATmega32.

2. JTag

Locate 5x2 male connector near the Green LED. Use any suitable JTAG programmer to program ATmega32.

3. Bootloader

This option is not supported with factory shipped AVRLiPV2 but you may use it if you replace / update the onboard ATmega32 with a bootloader.

| AVRLiP Assembly details www.deccanrobots.com | | | |
|--|---------------------------|----------|-------------------|
| Sr. Num | Item | Quantity | Ident Marking |
| 1 | IC ATmega32 | 1 | IC1 |
| 2 | IC DS1307 | 1 | IC2 |
| 3 | IC AT24C256 | 1 | IC3 |
| 4 | IC HIN232 | 1 | IC4 |
| 5 | LCD 16x2 | 1 | CON1 |
| 6 | LM 35 | 1 | S1 |
| 7 | TSOP1738 | 1 | S3 |
| 8 | IC Base 40 Pin | 1 | IC1 |
| 9 | IC Base 16 Pin | 1 | IC4 |
| 10 | IC Base 8 Pin | 2 | IC2, IC3 |
| 11 | 2 Pin Micro switch | 19 | SW1-SW19 |
| 12 | Cap 22/25V | 4 | C1, C2, C3, C4 |
| 13 | Cap 470/25V | 1 | C5 |
| 14 | Buzzer | 1 | PB1 |
| 15 | LDR | 1 | S2 |
| 16 | Cap 104 | 1 | C6 |
| 17 | Cap 22 | 2 | C7, C8 |
| 18 | Cap 1/63V | 1 | C9 |
| 19 | 3mm Red LED | 4 | D1, D2, D3, D4 |
| 20 | 3mm Green LED | 1 | D5 |
| 21 | MFR 1K | 3 | R2, R3, R4 |
| 22 | MFR 200 ohm | 1 | R6 |
| 23 | MFR 47K | 1 | R1 |
| 24 | RES 9Pin 1K | 2 | R9P-1, R9P-2 |
| 25 | MFR 10K | 1 | R5 |
| 26 | MFR 3.3K | 1 | R7 |
| 27 | BC548 | 1 | T1 |
| 28 | H-Preset-Philips 1K | 1 | VRES2 |
| 29 | H-Preset-Philips 20K | 1 | VRES1 |
| 30 | DB9-RightAngle-Female | 1 | CON5 |
| 31 | Female-Burgstrip 16pin | 1 | CON1 |
| 32 | Male Burgstrip 6 pin | 1 | ISP |
| 33 | Crystal 4MHz | 1 | X1 |
| 34 | Male Burg Strip 2 Pin | 3 | CON2, CON3 |
| 35 | Crystal 32.768KHz | 1 | X2 |
| 36 | Male Burgstrip 5 pins | 2 | CON6 |
| 37 | USB A type | 1 | CON4 |
| 38 | Jumper 2pin | 1 | With CON3 |
| 39 | Male Burgstrip 16pin | 1 | With LCD |
| 40 | Battery socket for CR2032 | 1 | Below PCB |
| 41 | PCB | 1 | DR-AVR-LIP-NI-1.0 |

DeccanRobots

India-Head Office

205, 2nd Floor, Decision Tower,
Next To CityPride,
Satara Road, Pune 411037
India
Tel: +91 (0)20 24228818
www.deccanrobots.com
support@deccanrobots.com

Disclaimer:

Neither this document nor the product AVR-LiP is guaranteed in any way. AVR-LiP is developed for learning purpose only. Usage of this product as a real life project is not recommended. DeccanRobots and their re-sellers are not responsible for any type of loss if occurs from usage of the document or the product AVR-LiP. ATMEL and AVR are the registered trademarks of ATMEL Corporation or its subsidiaries. Other product names may be trademarks of others.

